AMERICAN NATIONAL STANDARD

**TEST METHOD FOR THERMAL
TRANSMITTANCE AND
AIR INFILTRATION OF GARAGE DOORS
AND ROLLING DOORS**

ANSI-DASMA 105-2020

Door & Access Systems Manufacturers' Association, International

Sponsor:



1300 Sumner Ave
Cleveland, Ohio 44115-2851

AMERICAN NATIONAL STANDARD
**Test Method for Thermal Transmittance
and Air Infiltration of Garage Doors
and Rolling Doors**

Sponsor

Door & Access Systems Manufacturers' Association, International

American National Standard

American National Standard implies a consensus of those substantially concerned with its scope and provisions. An American National Standard is intended as a guide to aid the manufacturer, the consumer, and the general public. The existence of an American National Standard does not in any respect preclude anyone, whether he has approved the standard or not, from manufacturing, marketing, purchasing or using products, processes, or procedures not conforming to the standard. American National Standards are subject to periodic review and users are cautioned to obtain the latest editions.

CAUTION NOTICE:

This American National Standard may be revised or withdrawn at any time. The procedures of the American National Standards Institute require that action be taken to reaffirm, revise, or withdraw this standard no later than five years from the date of publication. Purchasers of American National Standards may receive current information on all standards by calling or writing the American National Standards Institute.

Sponsored and published by:
DOOR & ACCESS SYSTEMS MANUFACTURERS'
ASSOCIATION, INTERNATIONAL
1300 Sumner Avenue
Cleveland, OH 44115-2851
Phn: 216/241-7333
Fax: 216/241-0105
E-Mail: dasma@dasma.com
URL: www.dasma.com

Copyright © 2004, 2014, 2017, 2020 by Door & Access Systems
Manufacturers' Association, International
All Rights Reserved

No part of this publication may be reproduced in any form, in an electronic retrieval system or otherwise, without the prior written permission of the publisher.

Suggestions for improvement of this standard will be welcome. They should be sent to the Door & Access Systems Manufacturers' Association, International.

Printed in the United States of America

CONTENTS

PAGE

Foreword	v
1. Scope	1
2. Applicable Documents	1
3. Summary of Method	1-2
4. Significance and Use	2
5. Terminology	3
6. Apparatus	3-4
7. Calibration	4
8. Preparation of Test Specimen	4-5
9. Test Procedure	5-6
10. Calculations	6
11. Report	6-7

FIGURES

Figure 1 - Garage Door Installation, Thermal Transmittance Test	8
Figure 1A - Garage Door Installation, Air Infiltration Test	9
Figure 2 - Garage Door Thermocouple Locations	10
Figure 3 - Rolling Door Installation, Thermal Transmittance Test	11
Figure 3A - Rolling Door Installation, Air Infiltration Test	12
Figure 4 - Rolling Door Thermocouple Locations	13

Foreword (This foreword is included for information only and is not part of ANSI/DASMA 105, *Test Method for Transmittance and Air Infiltration of Garage Doors and Rolling Doors.*)

This standard was originally developed by the Technical Committee of the National Association of Garage Door Manufacturers and was approved as an American National Standard with the designation ANSI/NAGDM 105 - 1992. The Door & Access Systems Manufacturers' Association, International, (DASMA) was formed through the consolidation of two associations that served the garage door and operator industries for many years, NAGDM and the Door Operator & Remote Control Manufacturers Association (DORCMA).

The Technical Committee of the DASMA Commercial & Residential Garage Door Division reviewed the standard and made some modifications. DASMA employed the canvass method to demonstrate consensus and to gain approval as an American National Standard. The ANSI Board of Standards Review reaffirmed approval as an American National Standard on 11/30/20.

DASMA recognizes the need to periodically review and update this standard. Suggestions for improvement should be forwarded to the Door & Access Systems Manufacturers' Association, International, 1300 Sumner Avenue, Cleveland, Ohio, 44115-2851.

DASMA 105-2020
AMERICAN NATIONAL STANDARD
Test Method for Thermal Transmittance and Air Infiltration
of Garage Doors and Rolling Doors

1.0 SCOPE

1.1 The purpose of this test method is to measure the thermal characteristics of sectional garage doors and rolling doors under steady state conditions. Specifically, the measurements and calculations made will yield the steady-state thermal transmittance (U) using a hot box apparatus and the air infiltration rate.

1.2 In this test method, a perpendicular air flow is directed toward the exterior of the test specimen. The cold side air flow is adjusted so that the resulting exterior surface heat transfer coefficient of the calibration transfer standard (CTS) panel are within the established calibration limits.

1.3 Similarly, natural convection is simulated on the interior of the test specimen by applying a controlled downward flow of air over the face of the test specimen. The warm side air flow is adjusted so that the resulting interior surface heat transfer coefficient of the calibration transfer standard (CTS) panel are within the established calibration limits.

1.4 Prior to beginning the tests to determine thermal transmittance, a measurement is made to determine the air infiltration rate at test conditions. The results of thermal testing will not include the effects of heat loss due to air infiltration because the dynamic wind pressure of the exterior will be balanced to a zero differential pressure with a static air pressure on the interior, thereby intending to eliminate infiltration during testing.

1.5 The test facilities must conform to the calibration specifications contained herein to achieve reproducibility and comparability of results; however, the details of the test apparatus necessary to achieve these conditions may vary.

1.6 Those applying this test method shall be trained in the techniques of temperature measurement, shall understand the theory of heat flow, and shall have experience in thermal testing. Since it is undesirable to specify the construction of the test facility in such detail that it would unnecessarily restrict the method to a single arrangement, those applying the method shall have the technical competency to determine the accuracy and the operating variables of their respective test facilities, however, at a minimum the apparatus shall meet the requirements specified in ASTM C1363 for the design of a hot box apparatus.

2.0 APPLICABLE DOCUMENTS

- 2.1 ASTM E283 - Standard Test Method For Rate Of Air Leakage Through Exterior Windows, Curtain Walls, And Doors.
- 2.2 ASHRAE - Handbook Of Fundamentals
- 2.3 ASTM C1199 – Standard Test Method for Measuring the Steady-State Thermal Transmittance of Fenestration Systems Using Hot Box Methods
- 2.4 ASTM C1363 – Standard Test Method for Thermal Performance of Building Materials and Envelope Assemblies by Means of a Hot Box Apparatus
- 2.5 ASTM E1423 – Standard Practice for Determining Steady State Thermal Transmittance of Fenestration Systems

3.0 SUMMARY OF METHOD

3.1 To determine the thermal transmittance (U) of any specimen, it is necessary to know the area (A), the heat flow (Q), and the temperature differential (ΔT). The heat flux and the temperature differential shall be determined under conditions of steady state heat transfer. The test chamber shall establish and maintain the desired steady state

temperature difference across the test specimen for a period of time necessary to assure stabilization of heat transfer and to accurately measure the heat transferred for a specified time.

3.2 To determine the heat flow (Q), a five-sided metering box is placed around a test wall. A basic principle of the test method is to maintain a near zero temperature difference across the metering box wall. Adequate temperature controls and monitoring capabilities are essential. It is recognized that small temperature gradients could occur across the metering box walls due to the limitations of controllers and the effect of the convection currents adjacent to all surfaces of the metering box. Since the total wall area of the metering box is considerably larger than the metering area of the test specimen, small temperature gradients across the walls may cause a significant heat exchange to the metering box. For this reason, the metering box walls should be instrumented so that the heat flow through them can be calculated and a correction can be applied to the test results.

3.3 Moisture migration, condensation, and freezing on or within the specimen can cause variations in heat flow. To avoid this, the relative humidity in the warm room must be maintained at or below 15%. A relative humidity of less than 25% is permissible if interior surface temperatures of the specimen can be shown to be above the dew point.

3.4 Sectional garage and rolling door test specimens may have irregular surfaces and, therefore, do not have single inside and outside surface coefficients. The utilization of a calibration panel and the selection of, and adjustment to, representative surface coefficients provides the means by which dissimilar construction of the same general type can be compared under uniform test conditions, wherein the heat flow (Q) is the only unknown.

3.5 The intent of this procedure is to measure the thermal transmittance of test samples exposed to the same conditions. It is not intended to create uniform surface coefficients on the test specimens. Since many constructions have recesses that are not symmetrical, the use of parallel or angular air flows on the cold side of the test specimen could affect thermal transmittance and, in turn, affect the test reproducibility. A perpendicular air flow on the cold side is specified and very closely defined. The warm side surface coefficient is intended to be representative of natural convection, which generates a downward air flow parallel to the plane of the specimen on the warm side.

3.6 During the thermal test, this procedure neutralizes the effect of air infiltration by balancing the dynamic wind loading on the cold side with a static air pressure on the warm side. Therefore, thermal transmittance does not include heat loss due to air infiltration.

3.7 It is important to achieve precise calibration of cold side and warm side surface coefficients to insure consistent and reproducible test results. A pressure difference across the test specimen and variations in the water vapor content of the warm side air can cause errors in measuring heat flow; these variables must be reduced or eliminated to insure a reproducible test method.

4.0 SIGNIFICANCE AND USE

4.1 This test method applies only to vertically oriented constructions and is intended specifically for full sized sectional garage doors and rolling doors.

4.2 The thermal transmittance (U) can be used to compare different products of the same test size. Due to changes in the ratio of materials for different sized specimens having the same construction, the thermal transmittance will vary with test specimen size. Air infiltration rates are measured directly from the test specimen. For these reasons, this standard test method sets forth specific sizes and mountings for test specimens.

4.3 The exterior surface heat transfer coefficient is based on the ASHRAE recommendation and corresponds approximately to a 15 mph wind speed. The interior surface heat transfer coefficient is based on natural convection on a vertical surface. The tested U -factor does not include the effects of lower or higher average wind speeds. Consequently, the test value should be appropriately adjusted when used in estimating seasonal product performance.

4.4 The U -factor determined by tests at the standard test conditions can be used in estimating design loads for heating and cooling equipment of most low-rise residential buildings, since the surface coefficients are intended to be the same as those recommended in the ASHRAE method of calculating residential loads. Applicability of the tested U -factor to other building types should be determined by a competent engineer.

5.0 TERMINOLOGY

5.1 Thermal transmittance (U): The time rate of heat flow per unit area under steady state conditions from the air on the warm side of a body to the air on the cold side, per unit temperature difference between the warm and cold air. It is calculated as follows:

$$U = Q/A(T_h - T_c) \quad (5)$$

U is referred to as the overall coefficient of heat transfer and is commonly known as U-factor.

5.2 Symbols: The symbols used in the foregoing and subsequent paragraphs have the following significance:

U = thermal transmittance, Btu / hr sqft °F

Q = time rate of heat flow through area A,
Btu / hr

A = area of test frame opening normal to
heat flow, sqft

T_h = temperature of warm side air, °F

T_c = temperature of cold side air, °F

6.0 APPARATUS

6.1 The hot box apparatus is intended to subject a test specimen to differential interior and exterior temperatures and to accurately measure the thermal transmittance and surface temperatures of that specimen. The same apparatus, or another dedicated device, is intended to subject a test specimen to a differential pressure and accurately measure the air infiltration rate of that specimen.

6.2 Construction details, energy metering instrumentation, and controls are the responsibility of the test laboratory. These details shall conform to ASTM C1363 and ASTM C1199 requirements.

6.3 When the hot box apparatus is used to conduct air infiltration tests in accordance with ASTM E283, the cold and warm chambers shall be capable of withstanding internal and external pressures required by the test program. All joints, corners, and other openings shall be carefully and completely sealed. Alternatively, the air leakage testing may be performed using a dedicated air leakage testing device in accordance with ASTM E283.

6.4 Cold Chamber

6.4.1 A refrigeration unit and controls are required to automatically maintain a temperature of $-0.4^\circ \text{F} \pm 0.5^\circ \text{F}$.

6.4.2 A means of generating a uniform air flow of 15 mph shall be provided on the cold side. Air flow shall be perpendicular to the exterior surface of the test specimen. Horizontal centerline of discharge plenum shall coincide with the geometric horizontal centerline of the test specimen to insure a uniform air flow centered on the specimen.

6.5 Warm Chamber

6.5.1 A heating device and controls are required to automatically maintain a temperature of $69.8^\circ \text{F} \pm 0.5^\circ \text{F}$.

6.5.2 A system for controlling the humidity of the warm room air shall be provided. Relative humidity of the warm room shall not exceed 15% at any time during the test. A hygrometer for indicating the relative humidity is required. The instrument shall indicate relative humidity to within 1%. A relative humidity of less than 25% is permissible if interior surface temperatures of the specimen can be shown to be above the dew point.

6.6 Temperature Measuring Equipment

6.6.1 All thermocouples shall be Type T Special Limit of Error (SLE) thermocouple wire. Thermocouples used for the cold and warm room air measurements shall be 30 AWG or shall comply with ASTM C1363.

6.6.2 The cold room air temperature shall be determined by a thermocouple surrounded by a radiation shield and be located at the intersection of the vertical and horizontal centerlines and 3 inches perpendicular to the exterior plane of the test specimen. .

6.6.3 The warm room air temperature shall be determined by three (3) thermocouples surrounded by radiation shields. The center thermocouple shall be located at the intersection of the vertical and horizontal centerlines of the test specimen. One thermocouple shall be located 36" directly above and another directly below the center thermocouple. These three thermocouples shall be a distance of 3 inches perpendicular to the interior plane of the test specimen.

6.6.4 The interior surface temperatures of the test specimen shall be measured at locations representative of the different heat flow areas of the door. Figure 2 shows a recommended pattern for a garage door and Figure 4 shows a recommended pattern for a rolling door. These patterns are not required, but may be used as guidance to acceptable thermocouple placement.

6.6.5 The instrumentation shall indicate temperature readings of the thermocouples within 0.1° F.

6.6.6 Pressure Measuring Equipment

6.6.7 The air leakage testing apparatus shall include instrumentation capable of measuring the air leakage through the test sample within 5%.

6.6.8 The hot box apparatus shall be capable of measuring and maintaining a pressure differential across the separating wall within 0.002" H₂O.

6.6.9 The warm room air pressure detection shall be representative of overall room conditions and not located near any known sources of air movement.

7.0 CALIBRATION

7.1 The thermal test facility shall be calibrated with a CTS panel, constructed to establish cold and warm side surface coefficients, as prescribed in ASTM C1199. The CTS panel shall be positioned in a 4" thick surround panel recessed 1" from the exterior surface. The facility shall be calibrated prior to initial testing and annually thereafter. The facility shall also be recalibrated if changes or adjustments are made to the equipment or if test data appears questionable. The CTS panel shall not be smaller than 6'-6" by 6'-6".

8.0 SELECTION AND PREPARATION OF TEST SPECIMEN

8.1 Test specimens shall comply with the following size requirements for the product categories into which they fall (width x height):

Residential Garage Door:	10'-0" x 10'-0"
Commercial Garage Door:	10'-0" x 10'-0"
Rolling Door:	10'-0" x 10'-0"

8.2 The sectional garage door test specimen shall be installed per Figure 1 for U-factor testing and per Figure 1A for air infiltration testing. A mask shall be provided for installation of the test specimen per the details shown in Figures 1 and 1A. Exposed surfaces of the mask wall shall be white, or have an emissivity between 0.8 and 1.0. The rolling door specimen shall be installed per Figure 3 for U-factor testing and per Figure 3A for air infiltration testing.

8.3 For the thermal transmittance test, all joints, holes and openings in and around the test specimen shall be sealed at both the warm side and cold side surfaces. In addition, all applicable requirements of ASTM E 1423 shall be followed except where in conflict with the above language. Test specimen for the air infiltration test shall be prepared in accordance with ASTM E 283.

8.4 The test specimen shall be representative of manufacturer's production unit or identified as a prototype design. The manufacturer shall provide a complete set of detail drawings and material descriptions to the testing laboratory.

8.5 The test specimen shall be installed in accordance with the manufacturer's standard installation instructions, in the closed position. In no case shall the garage door be caulked to the test frame. Garage door horizontal track and balancing hardware are not required. Rolling door barrel, headplates and hood are not required in the thermal

transmittance test (see Figure 3). Rolling door barrel, headplates and hood are required in the air infiltration test (see Figure 3A). The rolling door shall be operable prior to the air infiltration test. Test framing construction shall be included in the test report.

9.0 TEST PROCEDURE

9.1 The standard test conditions required are:

Cold room temperature: $-0.4^{\circ}\text{F} \pm 0.5^{\circ}\text{F}$

Warm room temperature: $69.8^{\circ}\text{F} \pm 0.5^{\circ}\text{F}$

Cold room air flow: Perpendicular to specimen, producing a surface heat transfer coefficient of $5.28\text{ Btu/Hr-Ft}^2\text{-F} \pm 10\%$ (approximately 15 mph)

Warm room air flow: Downward flowing parallel to specimen, producing a surface heat transfer coefficient of $1.35\text{ Btu/Hr-Ft}^2\text{-F} \pm 5\%$ (natural convection)

Pressure difference across specimen: $0.000 \pm 0.002''\text{ H}_2\text{O}$

Interior Relative Humidity: less than 15%, but 25% RH allowable if surface temperatures are shown to be above dew point.

9.2 Inspect the test specimen for suitability for thermal testing. When it can be done satisfactorily, repair any damage incurred in shipment. Do not test a specimen if satisfactory repairs cannot be made.

9.3 Install the test specimen in the test wall with the outside face toward the cold room. Check the movable components to see that they are operational.

9.4 Air infiltration tests shall be performed on the specimen in accordance with ASTM E-283 at a differential pressure of 1.57 psf (representative of a 25 mph wind). This test may be performed within the hot box apparatus or using a separate air infiltration measuring device.

9.5 Thermocouple locations shall be selected to determine stabilized heat flow conditions. Refer to Figure 2 for garage doors, and Figure 4 for rolling doors, for guidance. The thermocouples should be carefully applied in the following manner:

- (a) Clean the surface area where the thermocouples are attached.
- (b) Attach the thermocouple with the lead wires counted vertically at the desired location with a 1" wide by 4" long piece of aluminum tape (Borden's Mystic #7452 or equivalent). Apply pressure to the tape with a small roller, back of finger, screwdriver, or other suitable tool, until it is evident the thermocouple is in direct contact with the surface. The tape shall have a surface emissivity matching the surface to be measured within ± 0.05 . For painted surfaces, the tape will need to be painted to achieve this.
- (c) Lead wires should be arranged to minimize interference with natural convection on the warm side.
- (d) Thermocouple location diagrams are given in Figures 2 and 4. For garage doors, the number and location of thermocouples may vary dependent upon the design of the door. Design parameters affecting thermocouple locations include but are not limited to various section profiles, thicknesses and heights. The test laboratory should coordinate the exact locations with the garage door manufacturer to yield repeatable results best representing the specific garage door design.

9.6 Adjust temperature controls for the warm room and the cold room to the standard test temperatures of 69.8°F and -0.4°F respectively. Adjust the relative humidity in the warm room to meet the RH requirements in Section 9.1. Turn on refrigeration, blower, and other necessary equipment. Adjust the pressure controls to provide a net total pressure difference across the test specimen of $0.000 \pm .002''\text{ H}_2\text{O}$.

9.7 Obtain stabilized temperature and heat flow conditions before beginning the calculation of the steady-state test period. Stabilized conditions are obtained when all heat flow readings made at 5 minute ± 5 second intervals are within 2% of the final average over a 2 hour period and are not unilaterally changing. Stabilized temperature conditions require that all readings be within 0.5°F .

9.8 Begin the test period to establish U factor rating when stabilized conditions are obtained. Record all temperature points, warm room relative humidity, pressure difference, and power reading at 5 minute ± 5 second intervals for two hours. Stabilized conditions, as defined in 9.7, must exist throughout the stability period and the test period.

9.9 When test is completed, shut the test chamber down, remove the test specimen and verify that the test specimen conforms to the drawings and specifications. 4"x4" specimens representing the slat or full door section, shall be sampled and stored for a minimum period of four years.

10.0 CALCULATIONS

10.1 Calculate U by means of equation (5), using the average values recorded during the 2-hour steady-state test period.

10.2 Take into account all extraneous heat losses and gains, as required by ASTM C1363.

11.0 REPORT

11.1 The test report shall include the following:

11.1.1 Name and location of testing laboratory, date when test was completed, date of issuance of the report, and names of individuals conducting and verifying the test. Latest calibration check date and procedure shall be noted.

11.1.2 Name of door manufacturer.

11.1.3 Series name, model number, and other identification of product tested.

11.1.4 Type, size, and description of test frame sill, test frame header, and test frame jambs.

11.1.5 "Inside" surface material and finish, facing type and thickness of facing to the nearest 0.01", as nominally reported by the manufacturer and verified by the test lab.

11.1.6 "Outside" surface material and finish, facing type and thickness of facing to the nearest 0.01", as nominally reported by the manufacturer and verified by the test lab.

11.1.7 Assembly drawing(s) of door as installed, including all sealing and caulking, with material descriptions to be provided by the manufacturer and verified by the testing laboratory. Detail drawings of the garage door sections/rolling door slats, including interfaces and seals, shall also be provided. A drawing of the specimen as tested for thermal transmittance shall be separate from a drawing of the test specimen as tested for air infiltration.

11.1.8 Type, description and complete dimensions (to the nearest 1/32 inch) of insulation.

11.1.9 Insulation density to the nearest 0.1 lbs. per cubic foot and, where applicable, blowing agent and chemical name/designation.

11.1.10 Warm surface temperatures.

11.1.11 Cold and warm room temperatures.

11.1.12 Overall test sample size and test opening size.

11.1.13 Overall garage door section panel / rolling door slat heights and quantity.

11.1.14 Surface thermocouple location diagram.

11.1.15 Warm room air humidity.

11.1.16 Thermal transmittance (U) of test specimen as calculated in section 10.1, to the nearest 0.01 BTU/hr-sf-°F.

11.1.17 Air infiltration rate at 1.57 psf (representative of a 25 mph wind) expressed in cu. ft/min/sq. ft. of test frame opening.

11.1.18 A statement that the tests were conducted in accordance with this Test Method and a list of any exceptions to standard conditions, sizes, or other specified criteria.

FIGURE 1 – GARAGE DOOR INSTALLATION
THERMAL TRANSMITTANCE TEST

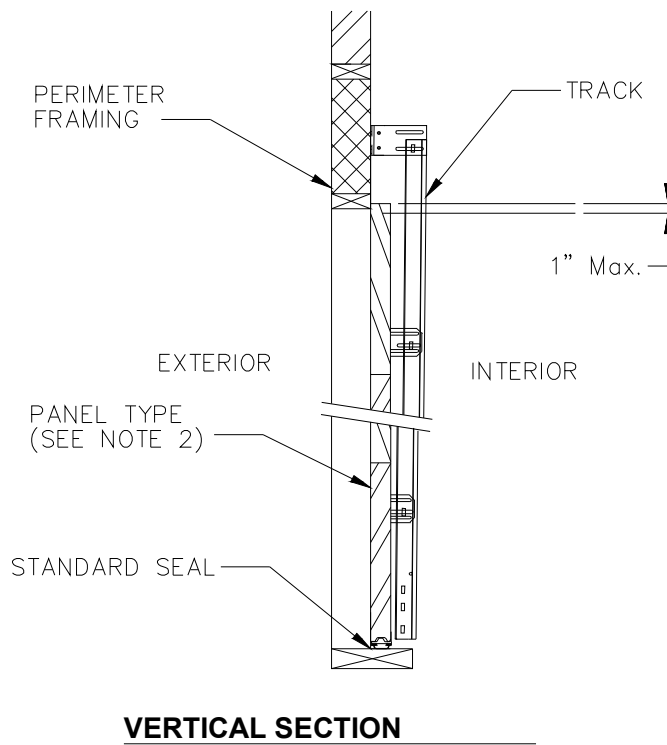
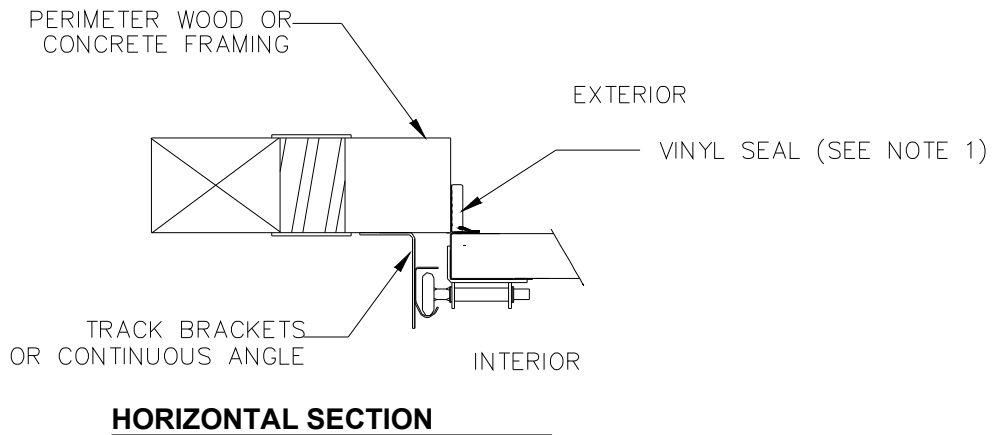

- NOTES:
1. SEAL SHALL BE INSTALLED SO AS TO ANTICIPATE MOVEMENT OF THE SPECIMEN DUE TO THERMAL STRESSES.
 2. PANEL HEIGHT AND NUMBER OF PANELS VARY DEPENDING ON DOOR DESIGN.

**FIGURE 1A – GARAGE DOOR INSTALLATION
AIR INFILTRATION TEST**

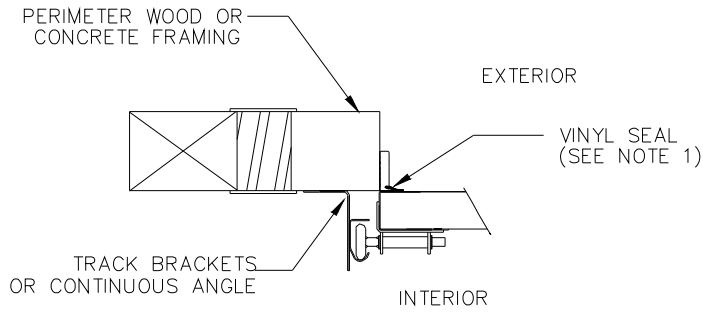

HORIZONTAL SECTION - Using Vinyl Seal

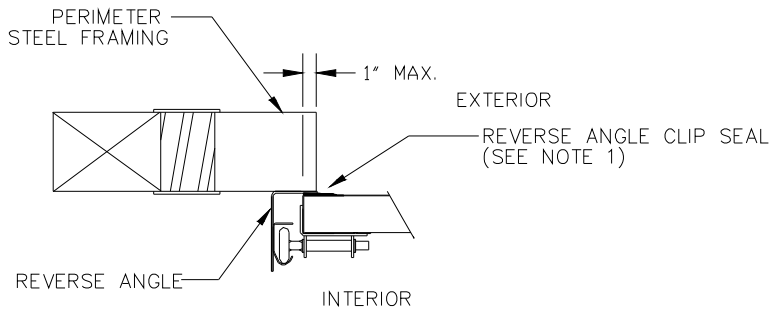

HORIZONTAL SECTION - Using Reverse Angle Clip Seal

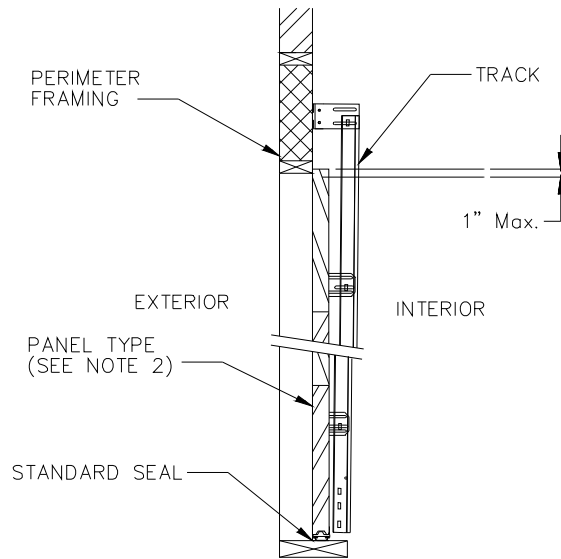

VERTICAL SECTION

- NOTES:
 1. SEAL SHALL BE INSTALLED SO AS TO ANTICIPATE MOVEMENT OF THE SPECIMEN DUE TO THERMAL STRESSES.
 2. PANEL HEIGHT AND NUMBER OF PANELS VARY DEPENDING ON DOOR DESIGN.

FIGURE 2 – GARAGE DOOR THERMOCOUPLE LOCATIONS

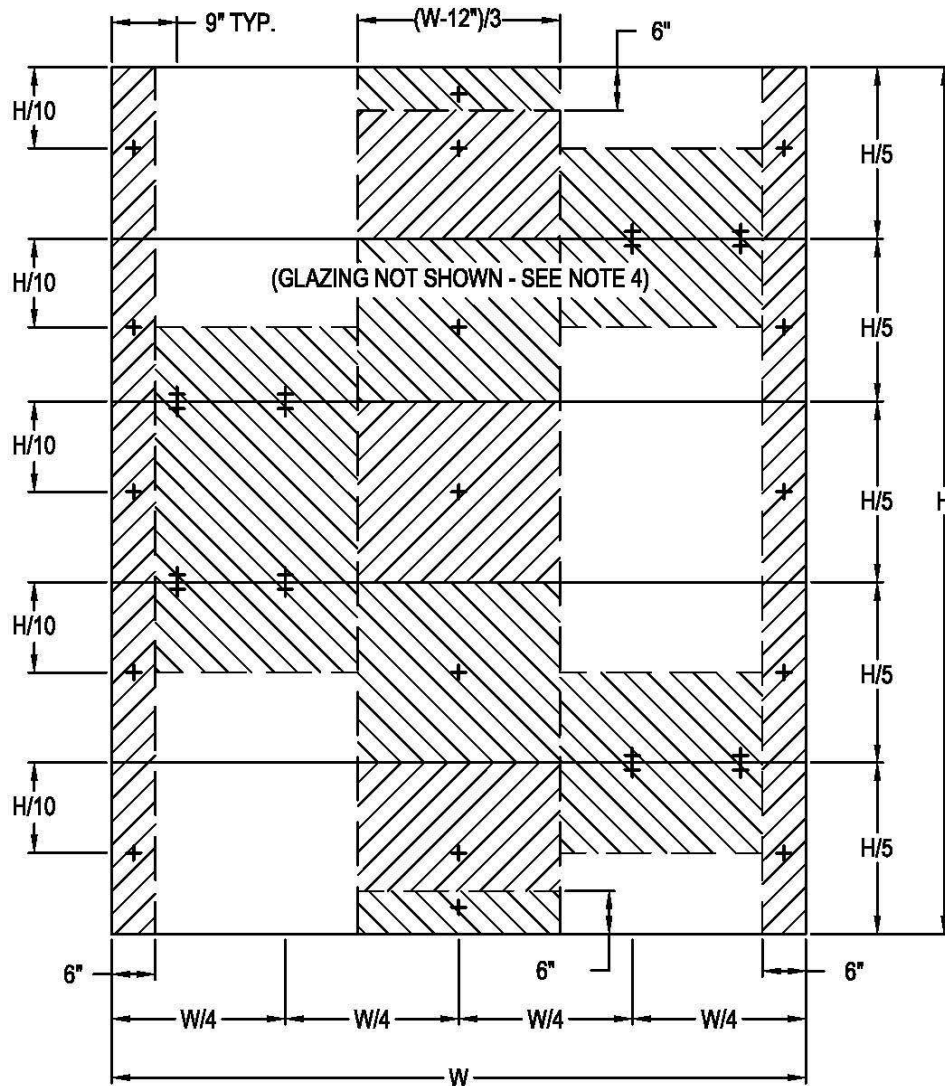

INTERIOR ELEVATION VIEW

NOTES:

1. PANEL PERIMETER THERMOCOUPLES SHALL BE LOCATED 3" FROM PANEL EDGES UNLESS OTHERWISE NOTED.
2. THERMOCOUPLES NEAR JAMB LOCATIONS SHALL BE PLACED ON PANEL SKIN MATERIAL AT THE THINNEST DOOR SECTION.
3. NUMBER AND LOCATION OF THERMOCOUPLES MAY VARY, DEPENDENT UPON THE DESIGN OF THE GARAGE DOOR.
4. WHEN GLAZING IS USED, THERMOCOUPLES FOR EACH LIGHT SHALL INCLUDE ONE IN THE CENTER AND TWO AT THE EDGES. ONE OF TWO AT THE EDGES SHALL BE LOCATED 1/2" FROM A LOWER CORNER AND THE SECOND SHALL BE LOCATED 1/2" FROM THE OPPOSITE UPPER CORNER.
5. TRIBUTARY AREAS INDICATE REPRESENTATIVE AREAS ASSOCIATED WITH THERMOCOUPLES IN SUCH AREAS, USED IN AREA-WEIGHTING CALCULATIONS.

FIGURE 3 – ROLLING DOOR INSTALLATION
THERMAL TRANSMITTANCE TEST

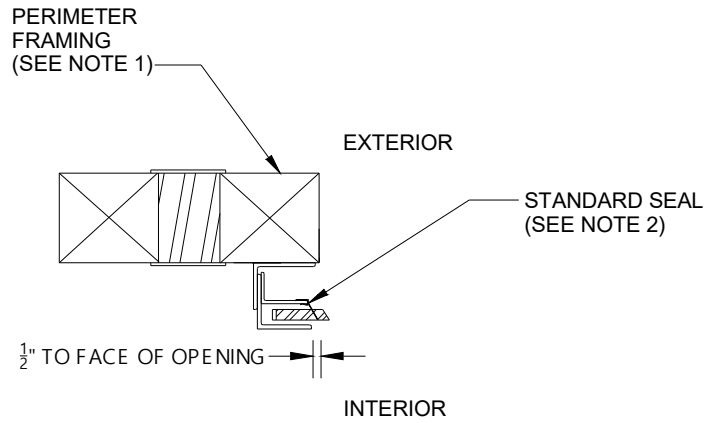

HORIZONTAL SECTION

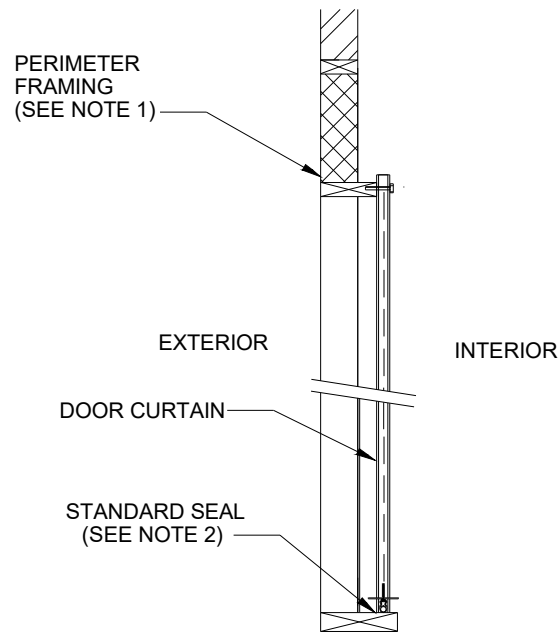

VERTICAL SECTION

- NOTES:
1. PERIMETER FRAMING MAY VARY TO ACCOMMODATE A SPECIFIC DOOR.
 2. SEAL SHALL BE INSTALLED SO AS TO ANTICIPATE MOVEMENT OF THE SPECIMEN DUE TO THERMAL STRESSES.

FIGURE 3A – ROLLING DOOR INSTALLATION
AIR INFILTRATION TEST

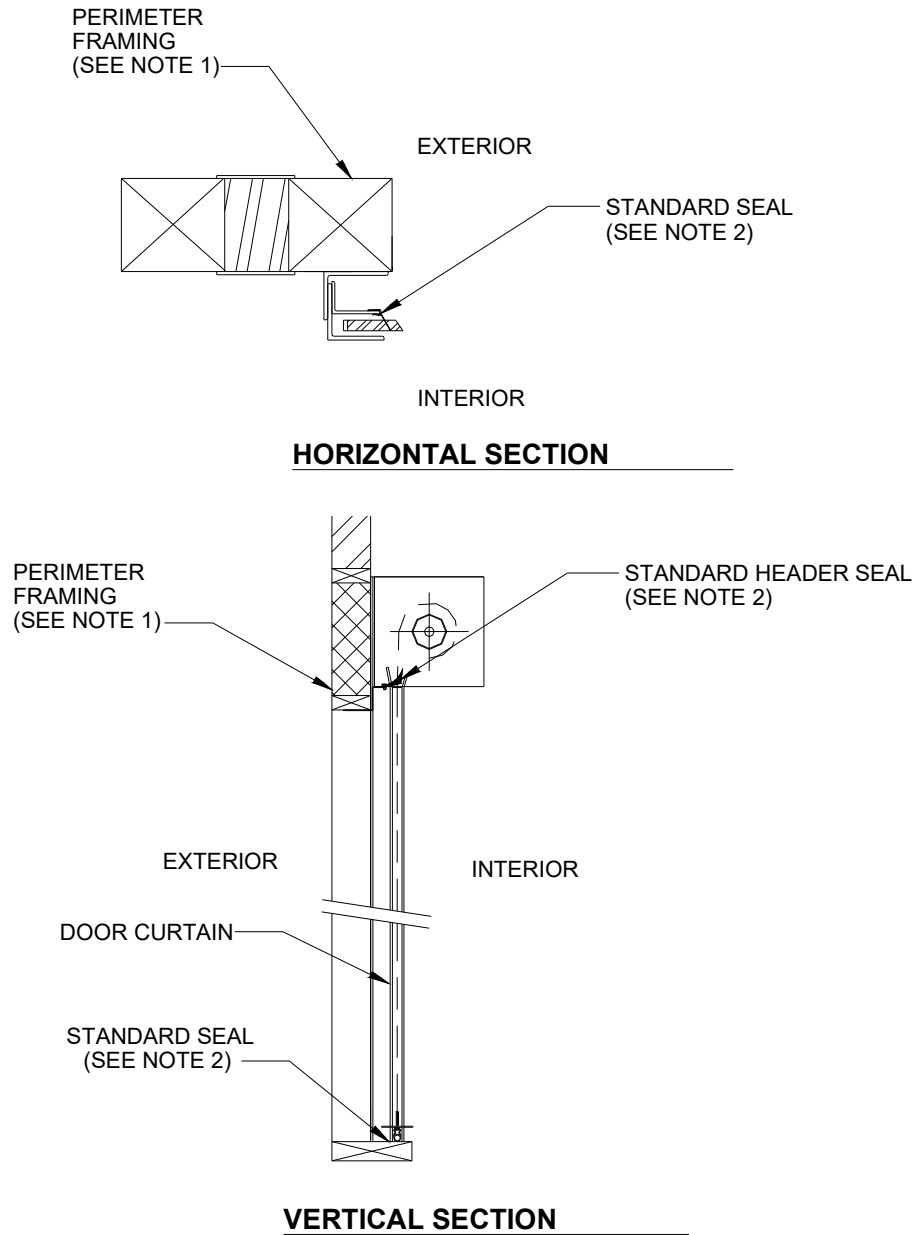

NOTES:

1. PERIMETER FRAMING MAY VARY TO ACCOMMODATE A SPECIFIC DOOR.
2. SEAL SHALL BE INSTALLED SO AS TO ANTICIPATE MOVEMENT OF THE SPECIMEN DUE TO THERMAL STRESSES.

FIGURE 4 – ROLLING DOOR THERMOCOUPLE LOCATIONS

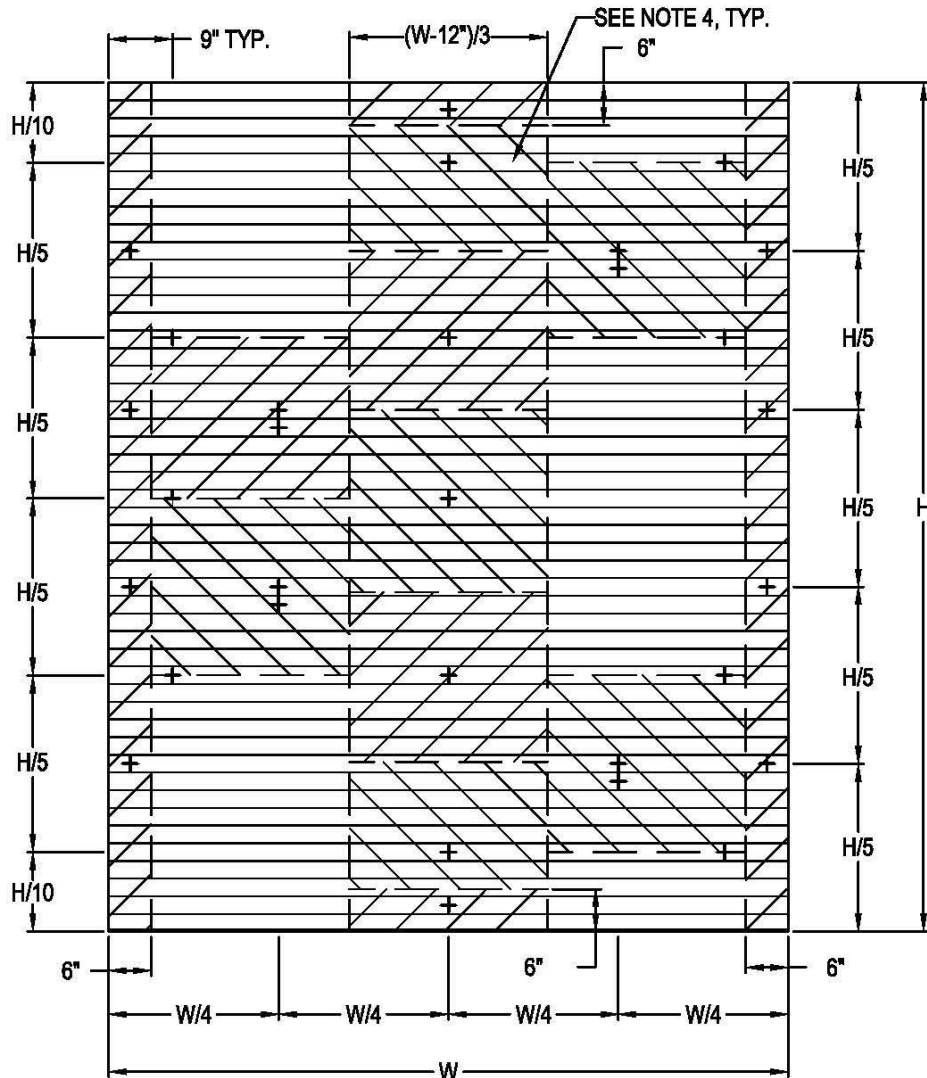

INTERIOR ELEVATION VIEW

NOTES:

1. DOOR PERIMETER THERMOCOUPLES SHALL BE LOCATED 3" FROM EDGES OF CLEAR OPENING UNLESS OTHERWISE NOTED.
2. DOOR THERMOCOUPLES SHALL BE CENTERED VERTICALLY ON EACH DOOR SLAT.
3. NUMBER AND LOCATION OF THERMOCOUPLE LOCATIONS MAY VARY, DEPENDENT UPON THE DESIGN OF THE ROLLING DOOR.
4. TRIBUTARY AREAS INDICATE REPRESENTATIVE AREAS ASSOCIATED WITH THERMOCOUPLES IN SUCH AREAS USED IN AREA -WEIGHTING CALCULATIONS.



DASMA – The Door & Access Systems Manufacturers Association, International – is North America’s leading trade association of manufacturers of garage doors, rolling doors, garage door operators, vehicular gate operators, and access control products. With Association headquarters based in Cleveland, Ohio, our 90 member companies manufacture products sold in virtually every county in America, in every U.S. state, every Canadian province, and in more than 50 countries worldwide. DASMA members’ products represent more than 95% of the U.S. market for our industry.

For more information about the Door & Access Systems Manufacturers Association, International, contact:

DASMA
1300 Sumner Avenue
Cleveland, OH 44115-2851
Phn: 216/241-7333
Fax: 216/241-0105
E-Mail: dasma@dasma.com
URL: www.dasma.com