DASMA STANDARD

**TEST METHOD FOR AIR LEAKAGE OF
SECTIONAL GARAGE DOORS,
ROLLING DOORS, AND FLEXIBLE DOORS**

DASMA 112-2023

Door & Access Systems Manufacturers' Association, International

Sponsor:



1300 Sumner Ave
Cleveland, Ohio 44115-2851

DASMA 112-2023

DASMA STANDARD Test Method for Air Leakage of Sectional Garage Doors, Rolling Doors, and Flexible Doors

Sponsored and published by:

DOOR & ACCESS SYSTEMS MANUFACTURERS' ASSOCIATION, INTERNATIONAL

1300 Sumner Avenue

Cleveland, OH 44115-2851

Phn: 216/241-7333

Fax: 216/241-0105

E-Mail: dasma@dasma.com

URL: www.dasma.com

Copyright © 2023 by Door & Access Systems Manufacturers' Association, International
All Rights Reserved

No part of this publication may be reproduced in any form, in an electronic retrieval system or otherwise, without the prior written permission of the publisher.

Suggestions for improvement of this standard will be welcome.

They should be sent to the Door & Access Systems Manufacturers' Association, International.

Printed in the United States of America

CONTENTS

PAGE

Foreword	iv
1. Scope	1
2. Applicable Documents	1
3. Summary of Method	1
4. Significance and Use	1-2
5. Terminology	2
6. Apparatus	2
7. Calibration	2
8. Selection and Preparation of Test Specimen	2
9. Test Procedure	2-3
10. Calculations	3
11. Report	3

FIGURES

Figure 1 - Sectional Garage Door Installation	4
Figure 2 - Rolling or Flexible Door Installation	5

Foreword (This foreword is included for information only and is not part of DASMA 112, *Test Method for Air Leakage of Sectional Garage Doors, Rolling Doors, and Flexible Doors.*)

This standard was created by three divisions of DASMA: the Commercial & Residential Garage Door Division, the Rolling Door Division, and the High Performance Door Division. The content was extracted from the American National Standard ANSI/DASMA 105 *Test Method for Thermal Transmittance and Air Infiltration of Garage Doors and Rolling Doors*, which was concurrently revised to remove the air infiltration content. Both standards were also extensively updated with the latest industry knowledge and according to the updated versions of the referenced documents, with assistance from industry stakeholders in the testing, inspection, and certification arenas.

The standard is being submitted to the American National Standards Institute in order to undergo the canvass process with the intention of DASMA 112 becoming a new American National Standard. DASMA's commitment to standards development by the consensus process has been demonstrated by the creation of nine (9) ANSI standards and many other industry standards over the course of 25 years.

DASMA recognizes the need to periodically review and update this standard. Suggestions for improvement should be forwarded to:

Door & Access Systems Manufacturers' Association, International
1300 Sumner Avenue
Cleveland, Ohio, 44115-2851.

DASMA 112-2023
Test Method for Air Leakage
of Sectional Garage Doors, Rolling Doors, and Flexible Doors

1.0 SCOPE

1.1 The purpose of this test method is to measure the air leakage characteristics of sectional garage doors, rolling doors, and flexible doors under steady state conditions.

1.2 Measurements and calculations shall be made to determine the air infiltration and air exfiltration rates at test conditions.

1.3 The test facilities must conform to the validation specifications contained herein to achieve reproducibility and comparability of results; however, the details of the test apparatus necessary to achieve these conditions may vary.

1.4 Those applying this test method shall be trained in the techniques of air leakage measurement. Since it is undesirable to specify the construction of the test facility in such detail that it would unnecessarily restrict the method to a single arrangement, those applying the method shall have the technical competency to determine the accuracy and the operating variables of their respective test facilities.

1.5 This standard uses the imperial system of units. Values shall be recorded and measurements shall be taken in that system. Values stated in the SI system, whether measured or obtained by unit conversion, are not necessarily exact equivalents; therefore, to ensure conformance with the standard, the SI system of units shall not be used.

2.0 APPLICABLE DOCUMENTS

2.1 REFERENCED DOCUMENTS

2.1.1 ASTM E283/E283M - *Standard Test Method for Determining Rate of Air Leakage Through Exterior Windows, Skylights, Curtain Walls, and Doors Under Specified Pressure Differences Across the Specimen*

2.2 OTHER APPLICABLE DOCUMENTS

2.2.1 ASHRAE - Handbook of Fundamentals

2.2.2 UL 1784 - *Standard for Air Leakage Tests of Door Assemblies and Other Opening Protectives*

2.3 Any undated reference to a code or standard appearing in the requirements of this standard shall be interpreted as referring to the latest edition of that code or standard.

3.0 SUMMARY OF METHOD

3.1 Seal a test specimen into or against one face of an air chamber.

3.2 Supply air to, or exhaust air from, the chamber at the rate required to maintain the specified test pressure difference across the specimen.

3.3 Measure the resultant air flow through the specimen.

4.0 SIGNIFICANCE AND USE

4.1 This test method is a standard procedure for determining air leakage under specified pressure differences at ambient conditions.

4.2 This test method applies only to vertically oriented partition constructions and is intended specifically for full sized sectional garage doors, rolling doors, and flexible doors.

4.2 Air infiltration and air exfiltration rates are measured directly from the test specimen. For this reason, this standard test method sets forth specific sizes and mountings for test specimens.

5.0 TERMINOLOGY

5.1 Air infiltration: Outside air transmitted into a building through a door opening area.

5.2 Air exfiltration: Inside room air transmitted out of a building through a door opening area.

5.3 Door opening area: The area (width x height) in ft² of the opening in the air chamber into or over which the door is mounted.

6.0 APPARATUS

6.1 Construction details and controls of the air leakage apparatus are the responsibility of the test laboratory.

6.2 The air leakage apparatus shall be in accordance with Section 6 *Apparatus* of ASTM E283/E283M.

7.0 VALIDATION

7.1 The validation of the test apparatus shall be performed in accordance with Section 9 *Validation* of ASTM E283/E283M.

8.0 SELECTION AND PREPARATION OF TEST SPECIMEN

8.1 The test specimen shall accommodate an opening size of 10'-0" high by 10'-0" wide.

8.2 The test specimen shall be installed onto a wood frame.

8.2.1 A sectional garage door shall be installed per Figure 1.

8.2.2 A rolling door or a flexible door shall be installed per Figure 2.

8.3 The test specimen shall be prepared in accordance with the applicable requirements of Section 8 *Test Specimen* of ASTM E283/E283M.

8.4 The test specimen shall be representative of the manufacturer's production unit or identified as a prototype design. The manufacturer shall provide a complete set of detail drawings and material descriptions to the test laboratory.

8.5 The test specimen shall be installed in accordance with the manufacturer's standard installation instructions, in the closed position. In no case shall the sections, slats, or panels, i.e., the movable portion of the door, be affixed to the guides, track, or test frame with tape, caulk or other sealant.

8.5.1 Garage door horizontal track and balancing hardware are not required.

8.5.2 Rolling door and flexible door barrel, headplates and hood are required, and these doors shall be operable prior to the air leakage test. Test framing construction shall be included in the test report.

9.0 TEST PROCEDURE

9.1 Air infiltration and air exfiltration tests shall be performed separately on the specimen in accordance with ASTM E283/E283M at a differential pressure of 1.57 psf.

9.2 When testing is completed, remove the test specimen and verify that the test specimen conforms to the drawings and specifications. The laboratory shall maintain representative samples (cut parts) of the door test specimens for a period of two (2) years after the test completion date. Samples shall represent or include interface or joint features of the test specimen section, panel, or slat, where applicable, and the test specimen end stiles or end locks, where applicable. The laboratory shall also maintain other pertinent documentation of the test including but not limited to data sheets, test reports, and pictures for a period of ten (10) years after the test completion date.

10.0 CALCULATIONS

10.1 Calculate air infiltration rate using measured data, to arrive at a number in terms of cubic feet per minute per square foot (cfm/ft²) of door opening area.

10.2 Calculate air exfiltration rate using measured data, to arrive at a number in terms of cubic feet per minute per square foot (cfm/ft²) of door opening area.

10.3 The calculations shall conform to Section 12 *Calculation* of ASTM E283/E283M.

11.0 REPORT

11.1 The test report shall include the following:

11.1.1 Name and location of test laboratory, date when test was completed, date of issuance of the report, and names of individuals conducting and verifying the test. Latest calibration check date and procedure shall be noted.

11.1.2 Name of door manufacturer.

11.1.3 Series name, model number, and other identification of product tested.

11.1.4 Type, size, and description of test frame sill, test frame header, and test frame jambs.

11.1.5 Assembly drawing(s) of door as installed, with material descriptions to be provided by the manufacturer and verified by the test laboratory. Detail drawings of the door sections or slats, including interfaces and seals, shall also be provided.

11.1.6 Where applicable, type, description and complete dimensions (to the nearest 1/32 inch) of insulation.

11.1.7 Where applicable, insulation density to the nearest 0.1 lbs. per cubic foot.

11.1.8 Overall test sample width and height and door opening area (see 5.3).

11.1.9 Overall door section or slat height(s) and quantity.

11.1.10 Warm room air humidity.

11.1.11 Air infiltration and air exfiltration at 1.57 psf expressed in cfm.

11.1.12 Air infiltration rate and air exfiltration rate at 1.57 psf, expressed in cfm/ft², using the leakages reported in 11.1.11 and the door opening area.

11.1.13 A statement that the tests were conducted in accordance with this test method and a list of any exceptions to standard conditions, sizes, or other specified criteria.

FIGURE 1 – SECTIONAL DOOR INSTALLATION

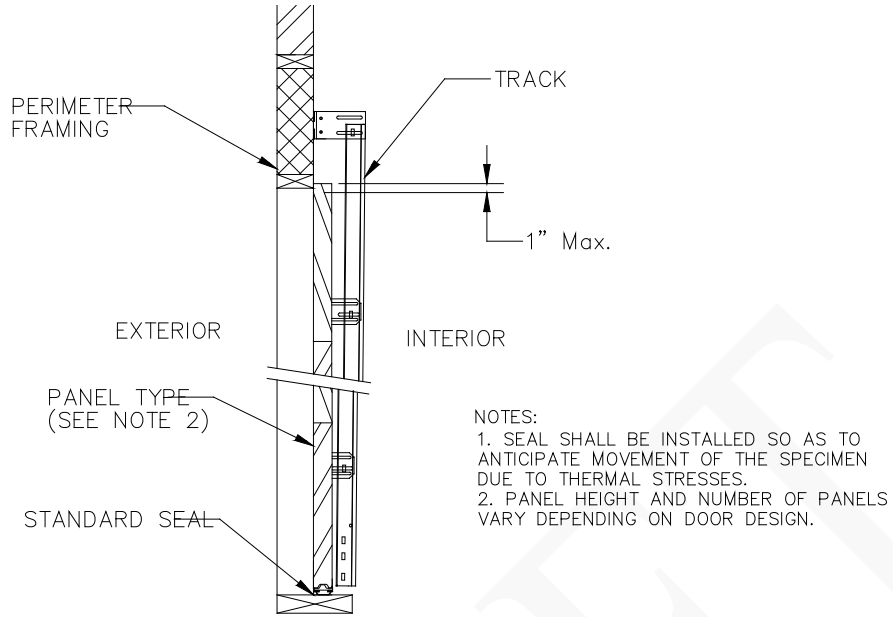

VERTICAL SECTION

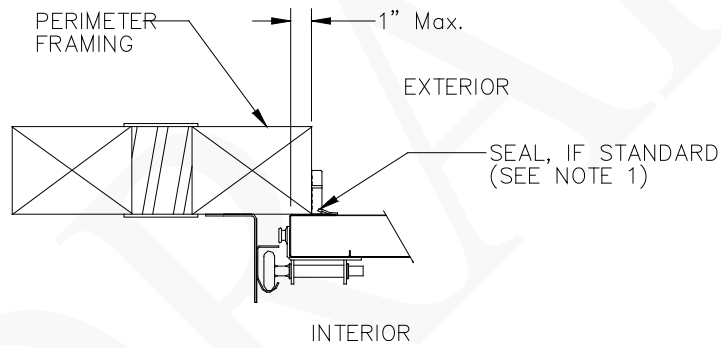

HORIZONTAL SECTION

FIGURE 2 – ROLLING OR FLEXIBLE DOOR INSTALLATION

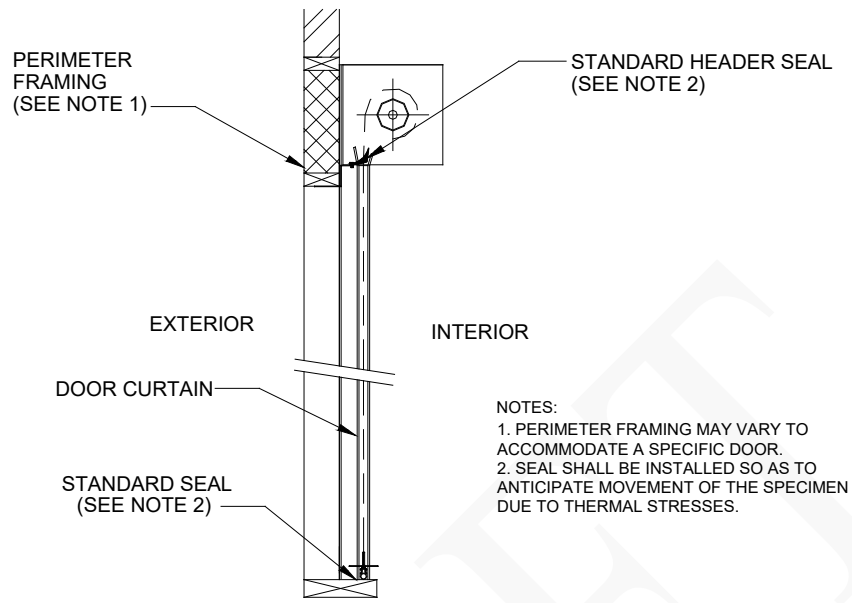

VERTICAL SECTION

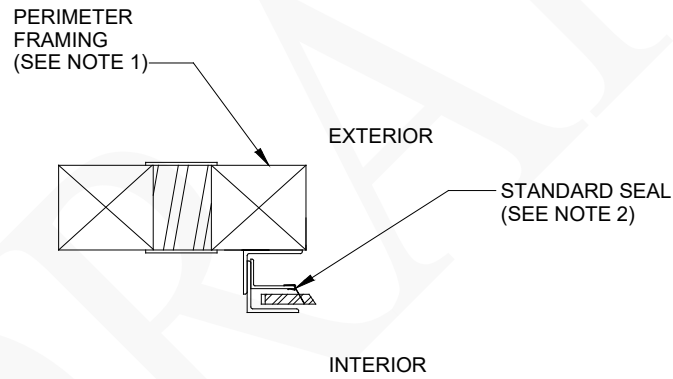

HORIZONTAL SECTION



DASMA – The Door & Access Systems Manufacturers Association, International – is North America’s leading trade association of manufacturers of garage doors, rolling doors, garage door operators, vehicular gate operators, and access control products. With Association headquarters based in Cleveland, Ohio, our 98 member companies manufacture products sold in virtually every county in America, in every U.S. state, every Canadian province, and in more than 50 countries worldwide. DASMA members’ products represent more than 95% of the U.S. market for our industry.

For more information about the Door & Access Systems Manufacturers Association, International, contact:

DASMA
1300 Sumner Avenue
Cleveland, OH 44115-2851
Phn: 216/241-7333
Fax: 216/241-0105
E-Mail: dasma@dasma.com
URL: www.dasma.com