



1300 Sumner Avenue
Cleveland, Ohio 44115-2851
Phone: 216-241-7333 • Fax: 216-241-0105
E-mail: dasma@dasma.com

Guidelines for Installation of Rolling Fire Door Release Assembly

Routing of the rolling fire door release assembly is a vital part of the fire door system. If the assembly is installed incorrectly, it may prevent the fire door from closing automatically. The provisions for installation of fusible links are found in the National Fire Protection Association Standard 80 (NFPA 80), Standard for Fire Doors and Other Opening Protectives. Below are the provisions from NFPA 80, 2019 Edition, for installing fusible links for fire doors. Figures referenced throughout this document can be found at the back of this document.

Section 4.7 Placement of Detectors

4.7.3.1 All detectors, including fusible links, shall be placed as shown in Figure 4 (Figure 4.7.3.1(a) in NFPA 80), but in no event shall detectors be placed in the dead air space area shown in Figure 4.

4.7.4.2 Unless otherwise acceptable to the AHJ, heat detectors or fusible links shall be installed on both sides of the wall, interconnected so that the operation of any single detector or fusible link causes the door to close.

4.7.4.3 Where fusible links are used, one fusible link shall be located near the top of the opening, and additional links shall be located at or near the ceiling on each side of the wall.

Appendix A

A4.7.4.2 The arrangements shown in Figures 2 and 3 are recommended to provide the performance intended. Other arrangements acceptable to the authority having jurisdiction could be permitted to be used.

A standard fire door release assembly consists of such typical components as fusible links, a cable or sash chain, S-hooks, turnbuckles, eyebolts, pulleys and steel through-wall sleeve.

Note: Technical Data Sheets are information tools only and should not be used as substitutes for instructions from individual manufacturers. Always consult with individual manufacturers for specific recommendations for their products and check the applicable local regulations.

This Technical Data Sheet was prepared by the members of DASMA's Rolling Door Division Technical Committee. DASMA is a trade association comprising manufacturers of rolling doors, fire doors, grilles, counter shutters, sheet doors, and related products; upward-acting residential and commercial garage doors; operating devices for garage doors and gates, sensing devices, and electronic remote controls for garage doors and gate operators; as well as companies that manufacture or supply either raw materials or significant components used in the manufacture and installation of the Active Members' products.

Basic Installation Guidelines to Follow

1. Read the manufacturer's instructions regarding the fire door release assembly.
2. Locate the first fusible link near the headplate(s) and allow for sufficient movement of the sash chain/cable to release the closing mechanism(s).
3. Locate the second fusible link within 12 inches of the ceiling on the door side of the wall. Do not install a link or detector within four inches of the intersection of the wall and the ceiling. (See Figure 4)
4. Locate the third fusible link on the opposite side of the wall at a distance from the wall that will allow sufficient travel of the sash chain or cable to completely release the fire door. Attach the fusible link near the ceiling straight out from the through-wall hole. The fusible link must be more than four inches from the intersection of the wall and ceiling. See "through-wall conduit installation information" on page 4. (Also see Figure 5)
5. Use 1/2 inch EMT conduit (per Figure 1) with sash chain or cable.
6. Use S-hooks for attaching fusible links. This will allow ease of installation and adjustments.
7. When routing cable or sash chain, do not make more than a 90-degree bend and use as few bends as possible.
8. Use turnbuckles to take up the slack in the cable or sash chain.
9. Attach eyebolts to the wall to help route the cable to a given location. Pulleys may have to be used in some circumstances.
10. The fusible links should be interconnected such that separation of any link will cause the door to close.
11. Request the authority having jurisdiction (AHJ) to approve routing of the fusible link assembly.
12. When the fire door is above a false ceiling, the fire door release assembly must not hang up on the ceiling construction. Consider using cable in lieu of sash chain in a location where the sash chain could snag or hang up on the ceiling construction. Beware of cable or turnbuckle hanging up above the ceiling.*
13. When using fusible links in conjunction with a temperature-activated sprinkler system, the following guidelines are recommended:
 - Do not locate fusible links in an area accessible to the sprinkler heads unless they are shielded from the water spray.
 - Coordinate the degree of activation between the two systems so that the activation temperature of the fire door is lower than the activation temperature of the sprinkler system.

It is important that cables or sash chains do not hang up on eyebolts or pulleys, through-wall holes or any other part of the building structure, or on headplate covers. Do NOT paint fusible links, sash chain or cable at any time.

The fire door mounting, headroom, wall & ceiling construction, building obstructions, and the fire door construction itself will determine how to route the fire door release assembly. There are two standard types of mounting conditions for a fire door. One is "face mounted" where the door is mounted on the face of the wall and with varying headroom conditions (See Figure 2). The other is "between jamb mounted" where the door is mounted between the jamb and under the lintel, where there is no additional headroom above the lintel (See Figure 3).

*For fire doors installed with the coil assembly above a false ceiling, fusible links/detectors may be required above and below the ceiling – consult the AHJ. If detectors are not required, their use is recommended to avoid installation / operation difficulties that may be encountered when locating fusible links above and below a false ceiling.

Note: Technical Data Sheets are information tools only and should not be used as substitutes for instructions from individual manufacturers. Always consult with individual manufacturers for specific recommendations for their products and check the applicable local regulations.

This Technical Data Sheet was prepared by the members of DASMA's Rolling Door Division Technical Committee. DASMA is a trade association comprising manufacturers of rolling doors, fire doors, grilles, counter shutters, sheet doors, and related products; upward-acting residential and commercial garage doors; operating devices for garage doors and gates, sensing devices, and electronic remote controls for garage doors and gate operators; as well as companies that manufacture or supply either raw materials or significant components used in the manufacture and installation of the Active Members' products.

Typical Questions Asked When Routing a Fusible Link Assembly

1. How do you interconnect the links when a door has a closing mechanism on each headplate?

Answer: One way is to first use one length of cable to connect the two mechanisms, locating a fusible link near one of the headplates. Then pull the center of the cable to a peak and connect a second cable using an S-hook. If there is enough headroom, run the cable assembly up near the ceiling and through the wall. The cable that connects the two mechanisms must be long enough to allow the fire door to release the drive headplate and the tension headplate.

2. How do you route cable through the wall without the cable hanging up?

Answer: One way is to use pulleys on both sides of the wall and to position them so one edge of the pulley is in line with the through-wall hole. Another way is to locate the through hole close to the ceiling. This will allow attachment of the eyebolts to the ceiling while positioning them in line with the through-wall hole.

3. What is the best solution for routing the fire door release assembly when obstructions exist between the fire door and the ceiling, or when the ceiling is too high for use of sash chain/cable?

Answer: Use detectors installed on both sides of the wall, located per Figure 4 and connected to a compatible release device or fire door motor operator, and install a fusible link or detector near the top of the opening.

Sash Chain and Cable Installation

DASMA participated in a test program conducted by an independent testing agency to evaluate various cable and sash chain materials that could be used in fusible link arrangements for rolling steel fire doors. Past studies of the performance of fire doors during annual testing of their automatic closing systems have consistently shown that snagged cable and sash chain arrangements are frequently noted as a reason why such a system did not operate properly.

The investigation evaluated the ability of various cable and sash chain materials and arrangements to maintain their flexibility and functionality to allow fire door automatic closing devices the freedom of movement needed to accomplish full closure of the door in fire or simulated fire situations.

Based on the results of the investigation, DASMA supports the following:

1. Plastic coated cable should not be used as part of the fire door release assembly.
2. Cable should be 7 x 19 stranded steel, either 3/32" or 1/8" diameter.
3. A sash chain used in a rolling fire door release assembly should be provided by the original fire door manufacturer.
4. For proper operation, do not locate the travel path of a fusible link close to an eyehook, wall penetration, or other obstruction.
5. When routing cable or sash chain, do not make more than a 90-degree bend.

Note: Technical Data Sheets are information tools only and should not be used as substitutes for instructions from individual manufacturers. Always consult with individual manufacturers for specific recommendations for their products and check the applicable local regulations.

This Technical Data Sheet was prepared by the members of DASMA's Rolling Door Division Technical Committee. DASMA is a trade association comprising manufacturers of rolling doors, fire doors, grilles, counter shutters, sheet doors, and related products; upward-acting residential and commercial garage doors; operating devices for garage doors and gates, sensing devices, and electronic remote controls for garage doors and gate operators; as well as companies that manufacture or supply either raw materials or significant components used in the manufacture and installation of the Active Members' products.

6. If sash chain is used, orient the small, folded end of the sash chain to be in the direction of release assembly movement.

Through-Wall Sleeve Installation

Where fusible links are installed on both sides of the wall, note the following per NFPA 80:

1. A sleeve shall be installed through the wall to provide an open pathway for the cable or chain connecting fusible links.
2. The sleeve shall be ½” galvanized steel conduit or pipe, with ends deburred, and fitting with a collar or bushing at each end to secure the sleeve around the wall and allow free movement of the cable or chain through the sleeve upon fusing of the links.

See Figure 1 for an illustration of these requirements.

Note: Technical Data Sheets are information tools only and should not be used as substitutes for instructions from individual manufacturers. Always consult with individual manufacturers for specific recommendations for their products and check the applicable local regulations.

This Technical Data Sheet was prepared by the members of DASMA's Rolling Door Division Technical Committee. DASMA is a trade association comprising manufacturers of rolling doors, fire doors, grilles, counter shutters, sheet doors, and related products; upward-acting residential and commercial garage doors; operating devices for garage doors and gates, sensing devices, and electronic remote controls for garage doors and gate operators; as well as companies that manufacture or supply either raw materials or significant components used in the manufacture and installation of the Active Members' products.

ROLLING DOOR DIVISION
TECHNICAL DATA SHEET
#254

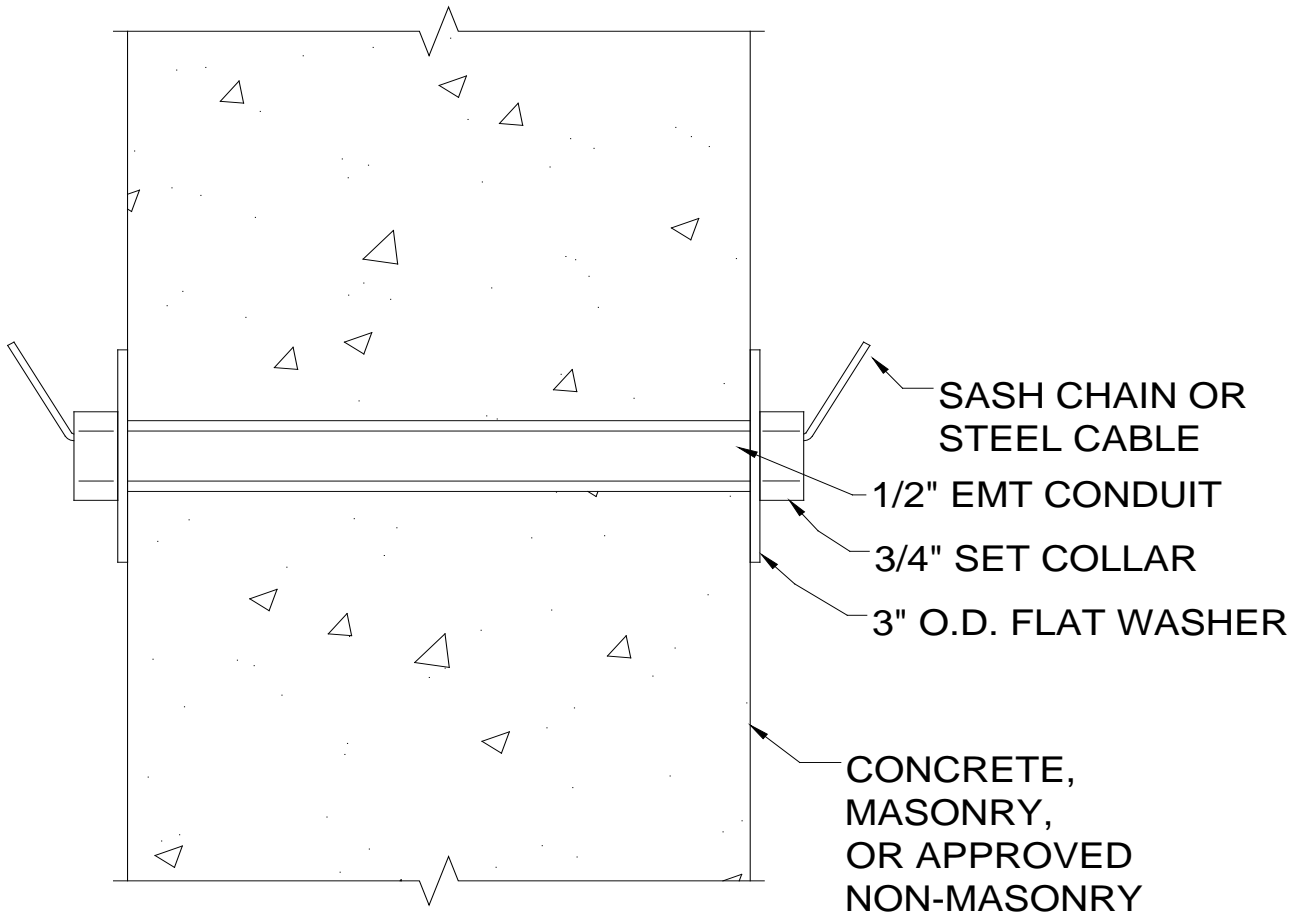
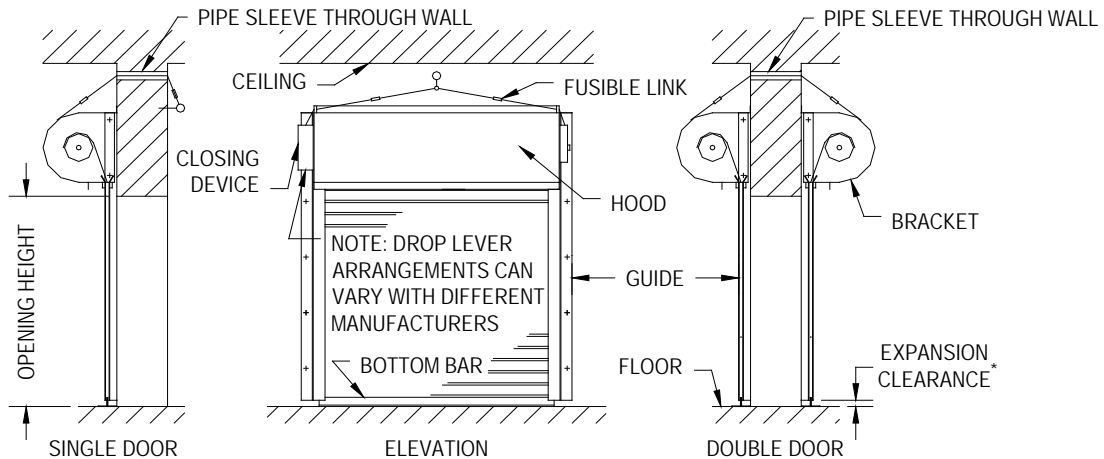

Figure 1
Through-Wall Sleeve Installation

Note: Technical Data Sheets are information tools only and should not be used as substitutes for instructions from individual manufacturers. Always consult with individual manufacturers for specific recommendations for their products and check the applicable local regulations.

This Technical Data Sheet was prepared by the members of DASMA's Rolling Door Division Technical Committee. DASMA is a trade association comprising manufacturers of rolling doors, fire doors, grilles, counter shutters, sheet doors, and related products; upward-acting residential and commercial garage doors; operating devices for garage doors and gates, sensing devices, and electronic remote controls for garage doors and gate operators; as well as companies that manufacture or supply either raw materials or significant components used in the manufacture and installation of the Active Members' products.

ROLLING DOOR DIVISION
TECHNICAL DATA SHEET
#254



*EXPANSION CLEARANCE PER DOOR LISTING. DOORS WITH DOWNWARD EXPANSION ARE AS SHOWN. DOORS WITH UPWARD EXPANSION REQUIRE EXPANSION CLEARANCE ABOVE THE TOP OF THE DOOR.

NOTE: FUSIBLE LINKS ARE NEEDED ON BOTH SIDES OF THE WALL - CONFIGURATION MAY VARY.

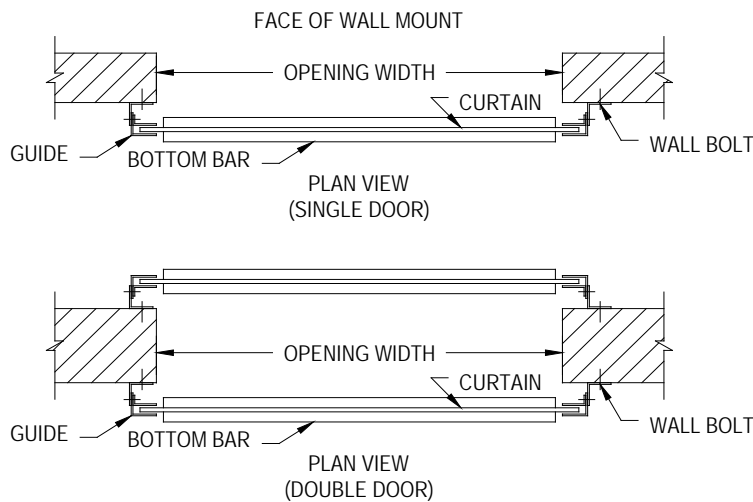
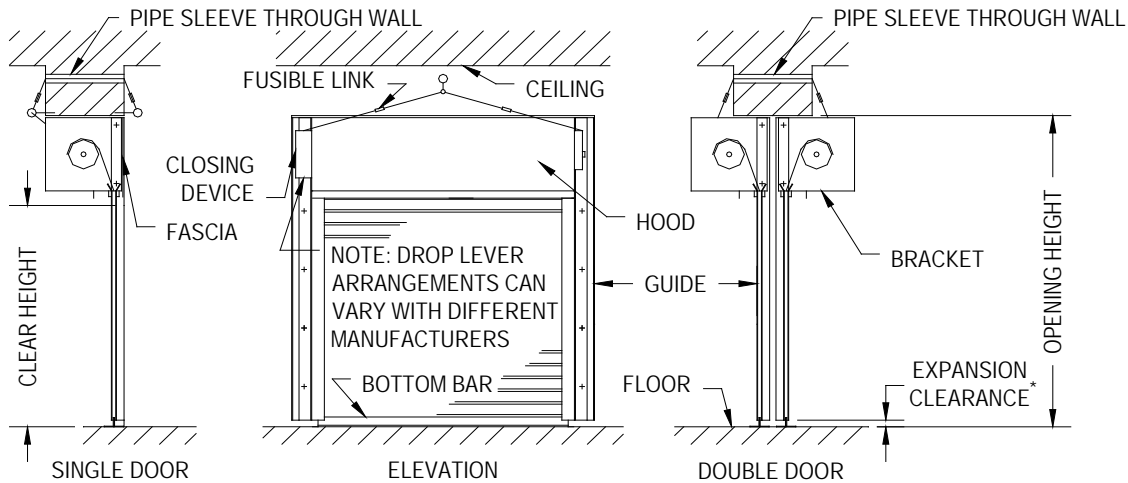

Figure 2
Rolling Steel Doors – Face Mounted (source: NFPA 80)

Note: Technical Data Sheets are information tools only and should not be used as substitutes for instructions from individual manufacturers. Always consult with individual manufacturers for specific recommendations for their products and check the applicable local regulations.

This Technical Data Sheet was prepared by the members of DASMA's Rolling Door Division Technical Committee. DASMA is a trade association comprising manufacturers of rolling doors, fire doors, grilles, counter shutters, sheet doors, and related products; upward-acting residential and commercial garage doors; operating devices for garage doors and gates, sensing devices, and electronic remote controls for garage doors and gate operators; as well as companies that manufacture or supply either raw materials or significant components used in the manufacture and installation of the Active Members' products.

ROLLING DOOR DIVISION
TECHNICAL DATA SHEET
#254



*EXPANSION CLEARANCE PER DOOR LISTING. DOORS WITH DOWNWARD EXPANSION ARE AS SHOWN. DOORS WITH UPWARD EXPANSION REQUIRE EXPANSION CLEARANCE ABOVE THE TOP OF THE DOOR.

NOTE: FUSIBLE LINKS ARE NEEDED ON BOTH SIDES OF THE WALL - CONFIGURATION MAY VARY.

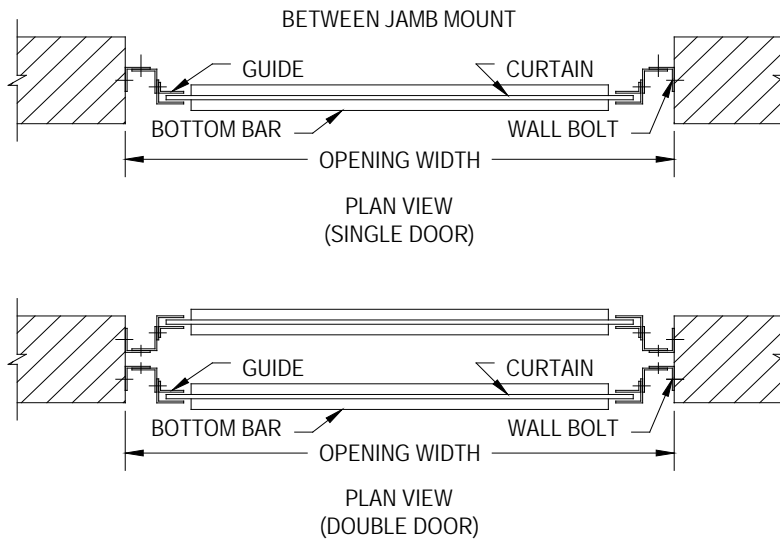

Figure 3
 Rolling Steel Doors – Between-Jamb Mounted (source: NFPA 80)

Note: Technical Data Sheets are information tools only and should not be used as substitutes for instructions from individual manufacturers. Always consult with individual manufacturers for specific recommendations for their products and check the applicable local regulations.

This Technical Data Sheet was prepared by the members of DASMA's Rolling Door Division Technical Committee. DASMA is a trade association comprising manufacturers of rolling doors, fire doors, grilles, counter shutters, sheet doors, and related products; upward-acting residential and commercial garage doors; operating devices for garage doors and gates, sensing devices, and electronic remote controls for garage doors and gate operators; as well as companies that manufacture or supply either raw materials or significant components used in the manufacture and installation of the Active Members' products.

ROLLING DOOR DIVISION
TECHNICAL DATA SHEET
#254

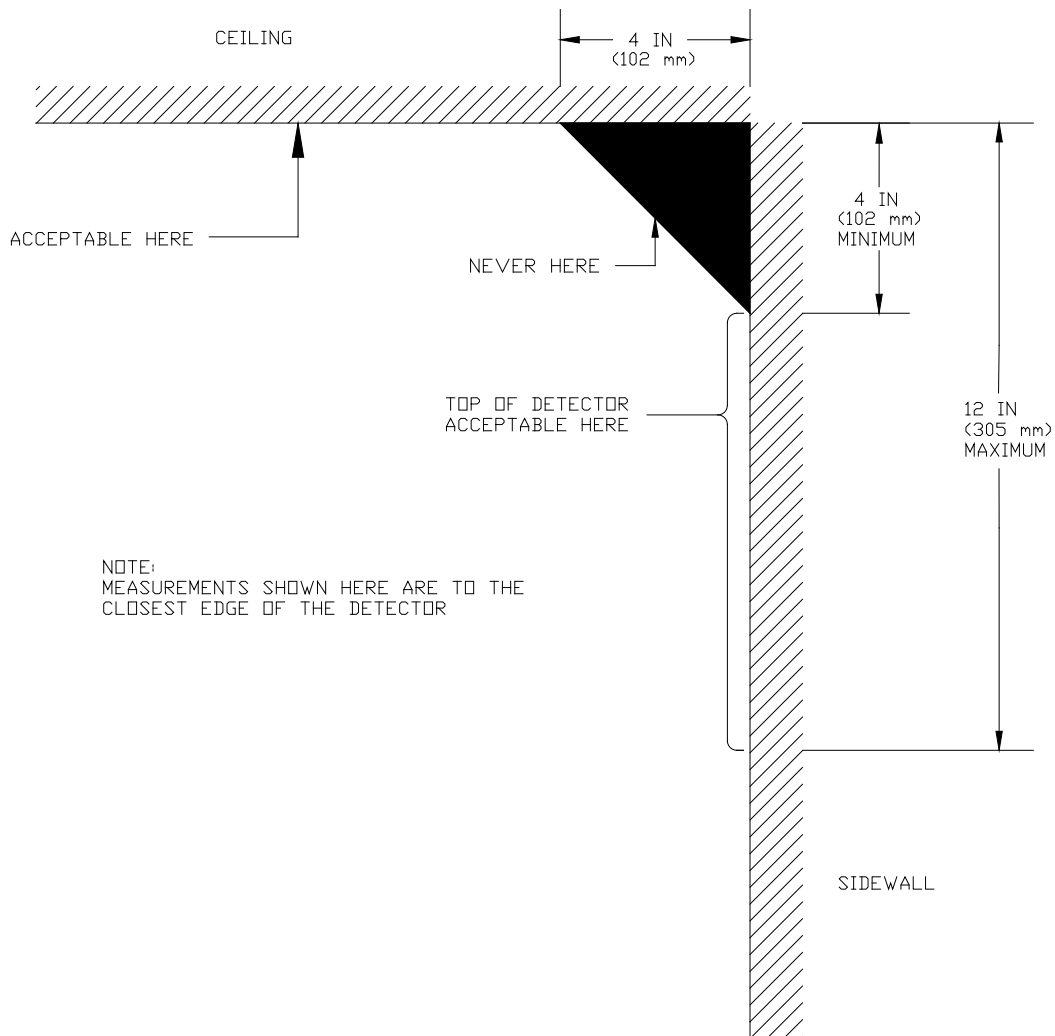

Figure 4
Example of Proper Mounting for Detectors

Note: Technical Data Sheets are information tools only and should not be used as substitutes for instructions from individual manufacturers. Always consult with individual manufacturers for specific recommendations for their products and check the applicable local regulations.

This Technical Data Sheet was prepared by the members of DASMA's Rolling Door Division Technical Committee. DASMA is a trade association comprising manufacturers of rolling doors, fire doors, grilles, counter shutters, sheet doors, and related products; upward-acting residential and commercial garage doors; operating devices for garage doors and gates, sensing devices, and electronic remote controls for garage doors and gate operators; as well as companies that manufacture or supply either raw materials or significant components used in the manufacture and installation of the Active Members' products.